

Low Value 3W Chip Resistors

LRF3W Series

- 3 Watts @ 70°C
- Resistance range from 0.003 to 1Ω
- Tolerances to ±1%
- AEC-Q200 Qualified

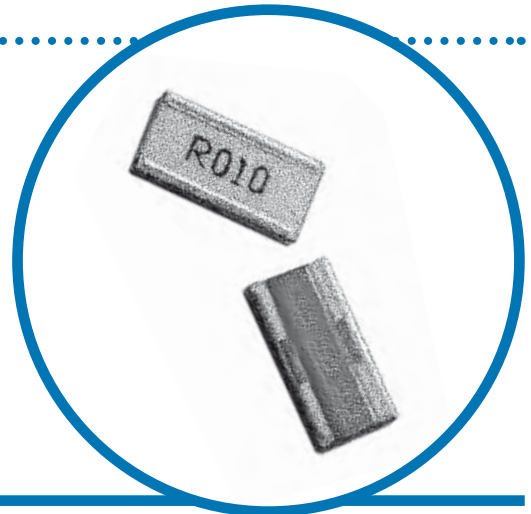

Electrical Data

Characteristic	Value
Power dissipation @70°C	3 Watts
Resistance Range	R003 to 1R0
Dielectric withstand	200V
Ambient temp range	-55 to +150°C
Resistance tolerance	≤R005 5%, >R005 2, 5%, ≥R01 1, 2, 5%
TCR	±100ppm/°C
Pad & trace area for maximum power rating*	300mm ²

Power Derating Curve

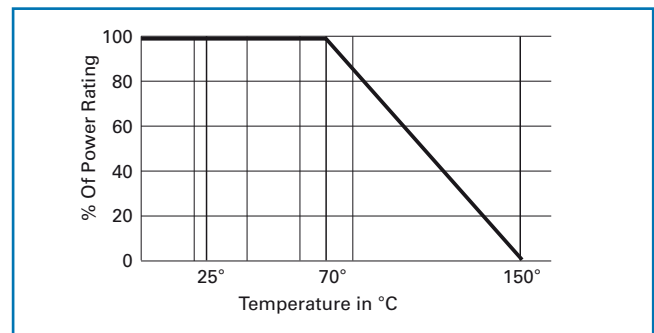

Physical Data

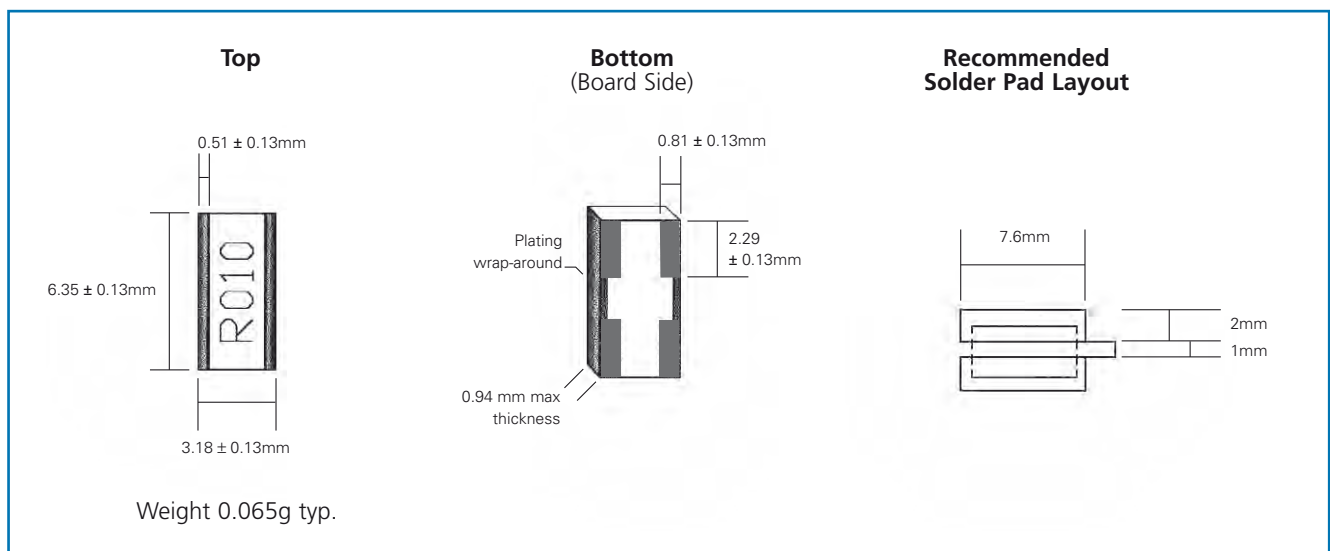

General Note

TT electronics reserves the right to make changes in product specification without notice or liability. All information is subject to TT electronics' own data and is considered accurate at time of going to print.

LRF3W Series

Construction

Patented non-noble copper based thick film material, overglaze and organic protection are screen printed on a 96% alumina substrate. The components are laser trimmed to achieve the required resistance tolerance.

Chips can withstand immersion in solder at 250°C for 90 seconds and are suitable for reflow or wave soldering mounting applications.

Terminations

The wrap-around terminations have an electroplated nickel barrier and matte tin finish, this ensures excellent 'leach' resistance properties and solderability.

Marking

The body protection and marking are resistant to all normal industrial cleaning solvents suitable for printed circuits. Chips are packed and mounted with marking side up. The LRF3W Chips are mounted with the actual resistor element mounted face down on its termination pads.

Performance Data

AEC-Q200 Table 7		Method	Max. (add R05)		Typ. (@R20)
ref	Test				
3	High Temp. Exposure	MIL-STD-202 Method 108	ΔR%	0.5	0.2
4	Temperature Cycling	JESD22 Method JA-104	ΔR%	0.25	0.1
6	Moisture Resistance	MIL-STD-202 Method 106	ΔR%	0.5	0.2
7	Biased Humidity	MIL-STD-202 Method 103	ΔR%	0.5	0.2
8	Operational Life (Cyclic Load)	MIL-STD-202 Method 108	ΔR%	1	0.5
14	Vibration	MIL-STD-202 Method 204	ΔR%	0.5	0.05
15	Resistance to Soldering Heat	MIL-STD-202 Method 210	ΔR%	0.25	0.05
16	Thermal Shock	MIL-STD-202 Method 107	ΔR%	0.25	0.1
18	Solderability	J-STD-002		>95% coverage	
21	Board Flex	AEC-Q200-005	ΔR%	0.5	0.2
22	Terminal Strength	AEC-Q200-006	ΔR%	0.25	0.1
	Short Term Overload	6.25 x Pr for 2s	ΔR%	0.5	
	Low Temperature Storage	-65°C for 100 hours	ΔR%	0.5	
	Shelf Life Test	Room temp for 12 months	ΔR%	0.1	
	Leach Resistance	Solder dip at 250°C		90s minimum	

Notes:

1. Full AEC-Q200 qualification applies to ohmic values $\geq R02$.

Packaging

LRF3W Resistors are supplied taped and reeled as per IEC 286-3. The standard quantity per reel is 1800 parts.

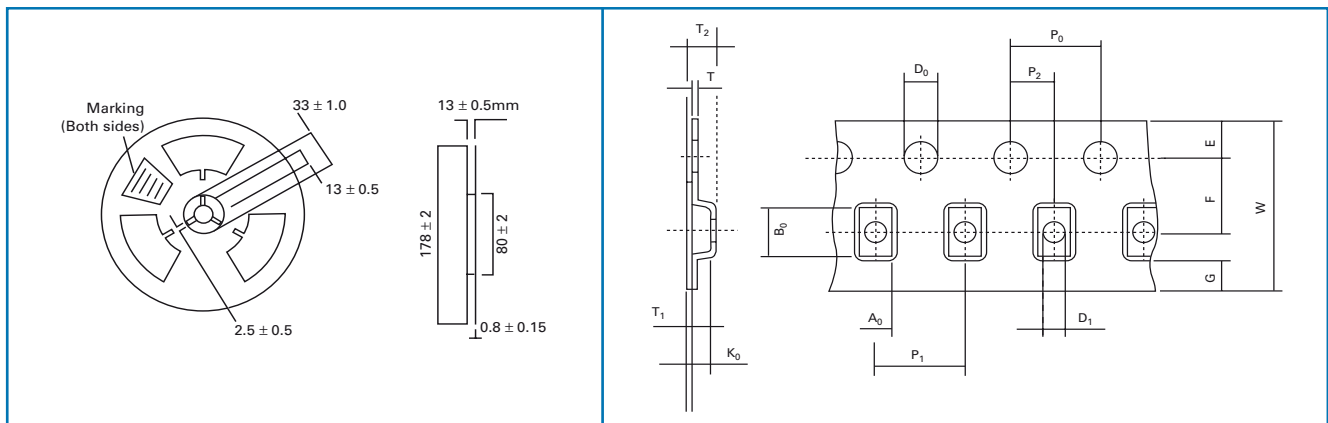

Tape dimensions in mm														
	W	P1	P0	P2	D0	D1	E	F	A0	B0	K0	T	T1	T2
	±0.3	±0.1	±0.1	±0.05	±0.1	±0.2	±0.1	±0.05	±0.1	±0.1	±0.1	±0.05	nom	±0.15
LRF3W	12	8	4	2	1.5	1.5	1.75	5.5	3.61	6.96	1.17	0.28	0.06	1.45

General Note

TT electronics reserves the right to make changes in product specification without notice or liability. All information is subject to TT electronics' own data and is considered accurate at time of going to print.



www.bitechnologies.com www.irctt.com www.welwyn-tt.com

Ordering Procedure

Specify type reference, value, tolerance and packing as shown in this example of LRF3W 5m 2% on a reel of 1800 pieces:

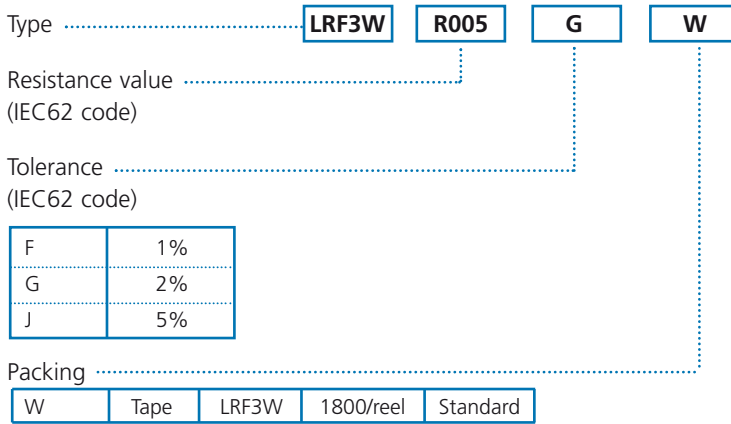

General Note

TT electronics reserves the right to make changes in product specification without notice or liability.
All information is subject to TT electronics' own data and is considered accurate at time of going to print.