

Defibrillator Case Study

In an effort to reduce the time-to-defibrillation interval and improve cardiac arrest survival, health service providers have increasingly turned to a strategy of wider access to defibrillation to augment emergency medical services. In some countries this is being implemented by providing automated external defibrillators (AEDs) for use by police, first aid volunteers and even members of the general public.



Two of the main improvements required to adapt hospital-based equipment were the miniaturisation of the defibrillator to a small portable device and its ability to withstand harsher temperature and humidity environments without effecting reliability.

To help in finding a viable solution to these requirements the Welwyn Applications Team were approached by one of the market leaders in the development and manufacture of AEDs. The

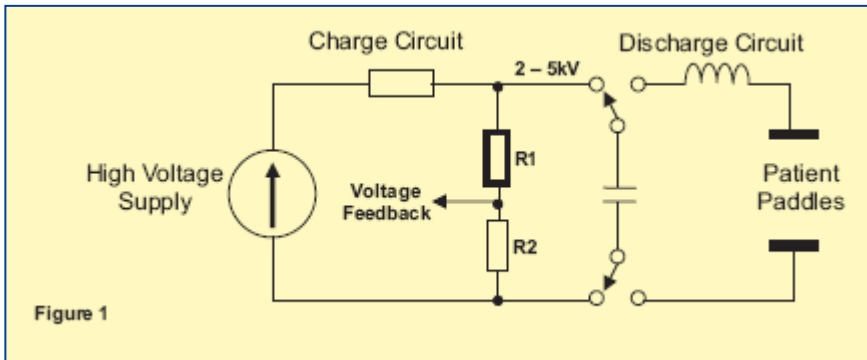

specific requirements of the project were to provide a high voltage resistor to be used in the defibrillator charge control circuit, see Figure 1.

The stable and repeatable measurement of the charging voltage is a critical function of this circuit, as this determines the amount of electrical energy delivered to the patient. In this instance R1 was a high voltage resistor with a value of 20M and 1% tolerance, which together with a standard chip resistor R2, forms a potential divider for voltage feedback.

In addition to the requirements for a physically smaller component and better environmental performance, the high voltage resistor needed to have excellent linearity, expressed by voltage coefficient (VCR) and temperature coefficient (TCR), and long term stability under voltage stress.

To overcome these problems the design team at Welwyn developed a new high-voltage planar resistor incorporating a printed thick-film resistor ink, based on a ruthenium oxide / glass system which is subsequently encapsulated with a specially formulated high-density epoxy protection which gives improved environmental performance over the traditional porous conformal coat protection.

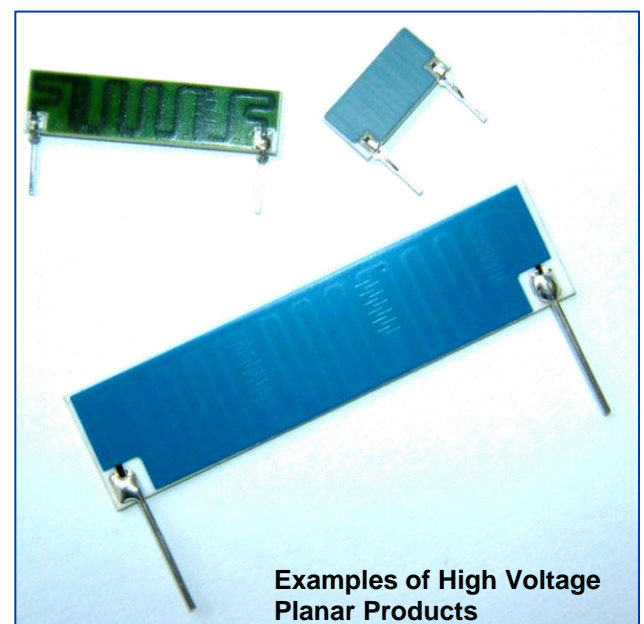

Martin Birkett
Applications Engineer Welwyn Components Ltd

Examples of High Voltage Planar Products