

RESISTORS FOR WELDING POWER SUPPLIES - Application Note

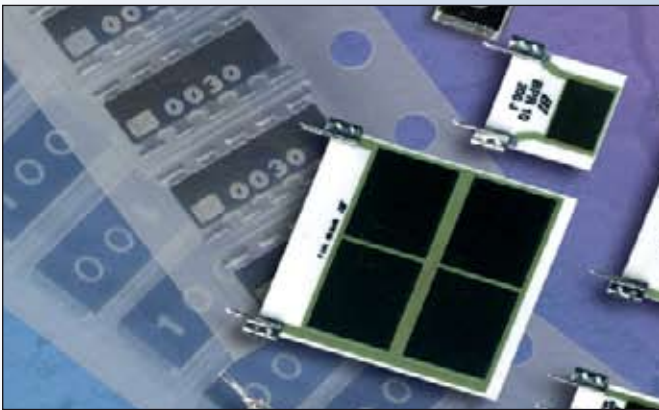

Power and Surge Resistors

Welding power supplies require robust power resistors for a range of functions which all share a common requirement; the dissipation of high power for a limited duration. It is necessary to understand the short term overload and surge capability of resistors selected for

these functions. This Application Note discusses the use of resistors in different types of welding power supply circuit and presents a selection of suitable products.



Applications

- Capacitor discharge
- Snubbing
- Inrush limiting
- MOSFET gate drive

Resistor Products

- Planar thick film
- Heatsink mountable
- Surge rated SMD

RESISTORS FOR WELDING POWER SUPPLIES - Application Note

1. Capacitor Discharge Resistor

The MIG arc welding power source shown has a secondary tapped transformer. It consists of a transformer, rectifier and output capacitor. The transformer should have separate primary and secondary windings so that the output is isolated from the power-line ground. The transformer primary to secondary turn ratio determines the amount by which the output voltage is stepped down. The rectifier is a full wave bridge of silicon diodes that converts the AC output voltage to DC and an output filter smooths the secondary voltage to give a more consistent weld. Using a switch that selects taps on the transformer mechanically controls the secondary output voltage. Increasing the number of secondary turns increases the secondary voltage. This control method has the advantage of being a robust and reliable design. The disadvantages are that the output voltage cannot be controlled remotely and input voltage fluctuations will affect the output. The output filter capacitor is sized on the

basis of the permissible output ripple voltage. To estimate the ripple, consider that the capacitor supplies the maximum output current I continuously, and is charged up to the output voltage every $1/100$ s for a fullwave rectifier (50Hz line frequency). The charge Q drawn by the load is $I/100$ s and equals $C\Delta V$, where ΔV is the peak to peak output ripple voltage. Thus, $C = I/100\Delta V$. The calculations result in large values of C typically a few 100,000 μF and the designs are implemented using large aluminium electrolytic capacitors. A bleeder resistor is connected across the output capacitor to discharge it when the supply is turned off and to remove the hazard of an unexpected voltage. The bleeder resistor should be rated to dissipate the necessary power in steady operation. Bleeder resistors used for this application have typical power ratings of 10 to 30 Watts. TT electronics BPC, BPR, MHP and BHPR power resistors can be used for this application.

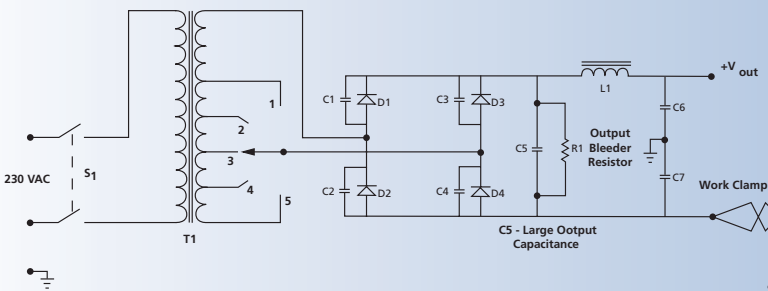

MIG arc welding power source - Transformer tapped

Primary side SCR phase angle control

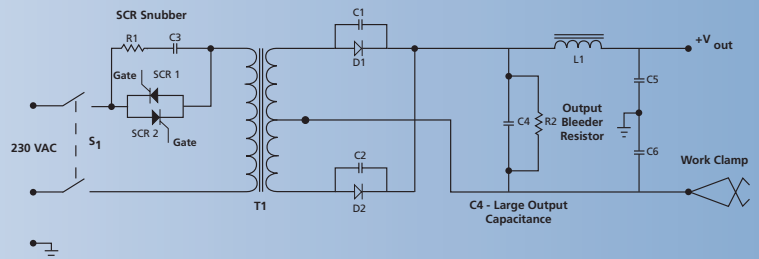

2. Snubber Resistor

The welding power source shown in the schematic above maintains a constant output voltage using an SCR control circuit. An SCR is a rectifier that remains in a nonconductive state, even when forward voltage is applied from anode to cathode, until a positive trigger pulse is applied to the gate and the SCR "fires". When the SCR "fires" it conducts current with a very low effective resistance, it remains conducting after the trigger pulse has been removed until the forward anode voltage is removed or reversed. The two SCR's in this design are connected in anti-parallel at the input to the transformer primary allowing power to be controlled during each half cycle of the AC input. The control circuit determines the firing time of the SCR trigger pulses and maintains a constant output voltage for changes in the line voltage and load current. Earlier firing times result in a greater fraction of half-cycle power being delivered to the load and a higher average DC output voltage. Sudden changes in line voltage or load current result in a correction in the timing of the next SCR trigger pulse that can be no further away that one half cycle (10ms for 50Hz input). A large filter capacitance across the rectifier output allows only a small change to occur during any 10ms

interval, avoiding the risk of transient dropout and loss of regulation due to sudden changes in load or line. The advantages with this type of power source when compared to the transformer tapped power source are that it requires fewer moving parts. It can be remotely controlled and voltage fluctuations at the input do not affect the weld output. Disadvantages are that it has poor efficiency, low power factor and a low speed of control. One further drawback with SCR converters is that a high rate-of-rise in anode-to-cathode voltage, or dV/dt , occurs when an SCR ceases conduction, or when another SCR in the circuit is gated into conduction. A high peak voltage is produced when an inductive circuit connected to the SCR is interrupted, for example the transformer leakage inductance. If the dV/dt is too large, the device will begin to conduct without a gate signal and will result in erratic circuit operation and potential device damage. A resistor capacitor snubber circuit connected across the SCR device can be employed to limit the SCR dV/dt and ensure reliable circuit operation. TT electronics BPR, BPC and MHP non-inductive resistors are suitable for this application.

RESISTORS FOR WELDING POWER SUPPLIES - Application Note

3. Inrush Current Limiting Resistor

Inrush current surges are caused by capacitor charging current and/or transformer magnetising current. The amplitude of the inrush depends where on the input voltage waveform the circuit is switched in. The inrush lasts for a short duration however can be many times greater than the steady state operating current. Large inrush currents can result in nuisance tripping of supply breakers, blown fuses or even permanent damage to the input circuit components. Solutions for limiting inrush transients range from the use of positive temperature co-efficient resistors to “soft-start”

techniques that gradually ramp up the power source input current. Few of these solutions meet all of the important criteria of reliability and low cost. Our example circuit shows a thyristor rectifier welding power source that utilises a low value resistor in series with the transformer primary to limit the initial inrush current surge. After a short delay the relay contacts close short circuiting the resistor. The relay contacts must be rated for the full mains voltage and steady state input current. TT electronics BPC, BPR and MHP power resistors can be used for this application.

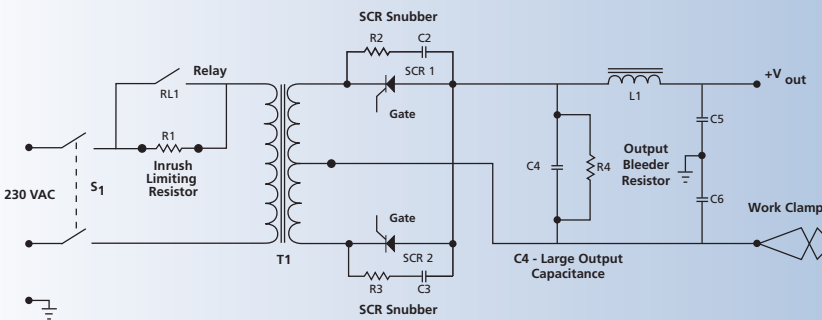

Secondary side phase angle control SCR

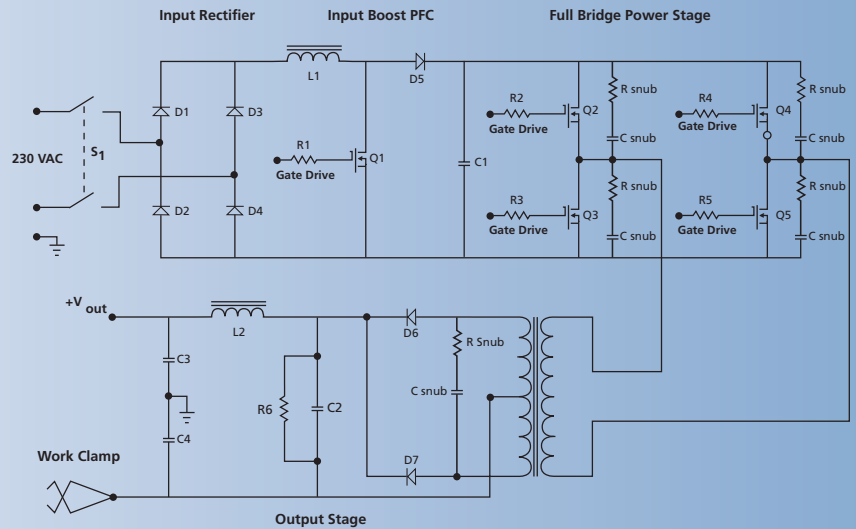





High frequency multi-process inverter welder

4. Gate Drive Resistors

The example above shows the circuit topology for an inverter welding power source. The input power is rectified to DC using a power factor correction boost converter. A full bridge MOSFET power stage converts the voltage back to AC at high frequency typically 50KHz to 100KHz. The transformer steps down the voltage, which is then rectified and smoothed at the output stage. The advantages of this type of power source are that it has high power conversion efficiency. And due to the high frequency operation of the MOSFET bridge the size of the components can be greatly reduced specifically the transformer and output filter stage. This is because the component size is inversely proportional to the operating frequency. The inverter power source maintains a constant output voltage regardless of changes in input voltage and output current. It has a very quick response time to changes in line and load and produces excellent arc characteristics delivering a true multi-

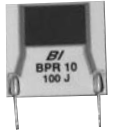
process capability. MOSFET switching losses are due to delays in the switching transients since during these short time intervals a finite voltage and current coexist in the device. Therefore switching speed is the most important criteria required to minimise switching losses. Consequently faster switching speeds correspond to an increase in di/dt of the drain/collector current. Fast di/dt coupled with stray circuit inductance can cause considerable problems such as increased radiated EMI, large voltage spikes and circuit oscillations. Adding a small resistance at the MOSFET gate can be used to trade efficiency for lower di/dt and its associated benefits. Resistors used for this application require high repetitive surge capabilities since they are expected to rapidly charge then discharge a MOSFET's input gate capacitance at a high frequency. TT electronics PWC, CHP and DSC SMD resistors are suitable for this application.

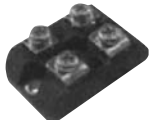
RESISTORS FOR WELDING POWER SUPPLIES - Application Note

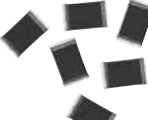
	BPC	BPR	MHP	BHPR	PWC	CHP	DSC
							
Power Rating (W)	3 - 10	3 - 50	20 - 140	250 - 300	0.125 - 1.5	0.25 - 1.33	0.33 - 1.5
Value Range	0R1 - 200K	0R1 - 200K	0R01 - 51K	0R01 - 51K	1R0 - 10M	0R1 - 2M2	1R0 - 4M7
Technology	Thick film	Thick film	Thick film	Thick film	Thick film	Thick film	Thick film
Format	Through hole	Through hole	Through hole heatsink	Off PCB heatsink	SMD	SMD	SMD
Package	Planar radial	Planar radial	TO126, TO220, TO247	TO227	Flat chip 0805, 1206, 2010, 2512	MELF 1206, 2010, 2512, 3610	Flat chip 0805, 1206, 2010, 2512
Features	Small footprint	Vibration resistant	High power	High power	Pulse withstanding chip	Cylindrical high pulse	Double sided chip

www.ttelectronics.com

www.bitechnologies.com

www.irctt.com

www.welwyn-tt.com

Europe: sales@ttelectronicseurope.com

Asia: sales@ttelectronicasia.com

Americas: sales@ttelectronics-na.com



TT electronics companies

General Note

TT electronics reserves the right to make changes in product specification without notice or liability. All information is subject to TT electronics' own data and is considered accurate at time of going to print.